

**DEVELOPMENT OF 10 KV MV NETWORK
ON THE TERRITORY OF BELGRADE
AFTER PRINCIPAL COMPUTER CONSIDERATIONS
D.Milanov, T.Milanov
„Elektrodistribucija Beograd“, Beograd.Serbia**

Abstract:

This paper presents the measures taken on the consumer area EDB in particular on the territory of the city municipality Stari Grada and whole center of Belgrade, to manage 10 kV MV network based on principal considerations on the computer from the 90's of the last century; the development of MV network in the very center of Belgrade starting from 1932 to 2000, which holds today extremely stabile development, which implied management of 10 kV network where maximum of 8 TS 10/0,42 kV having the total installed power of about 4,5 MVA – out of possible 12 TS having the total installed power of about 7,5 MVA, were distributed on all connection 10 kV lines.

Key words : *power distribution system, medium voltage network, arrangement of MV network*

**RAZVOJ SREDNJENAPONSKE MREŽE 10 KV
NA GRADSKOM PODRUČJU BEOGRADA
POSLE PRINCIPSKIH ANALIZA NA RAČUNARU
D.Milanov, T.Milanov
PD „Elektrodistribucija Beograd“**

Kratak sadržaj:

Ovaj rad prikazuje mere koje su preduzete gradskom delu konzuma PD „Elektrodistribucije Beograd“ (u daljem tekstu EDB) , na teritoriji opštine Stari grad i kompletnom strogom centru Beograda, na oblikovanju srednjenaponske mreže 10 kV na osnovu računarskih programa razvijenih u EDB početkom devedesetih godina prošlog veka. Prikazuje se razvoj mreže od 1932. do 2000. godine , danas sa najviše 8 TS 10/0,42 kV instalisane snage oko 4,5 MVA na poveznim vodovima – a sa mogućim 12 TS 10/0,42 kV ukupne instalisane snage oko 7,5 MVA.

Ključne reči : **Elektrodistributivne mreže, srednjenaponske mreže, oblikovanje mreže**

**DEVELOPMENT OF 10 KV MV NETWORK
ON THE TERRITORY OF BELGRADE
AFTER PRINCIPAL COMPUTER CONSIDERATIONS
D.Milanov, T.Milanov
„Elektrodistribucija Beograd“, Beograd.Serbia**

Introduction

The past development of medium-voltage networks in the urban consumer supply area within the Company ELEKTRODISTRIBUCIJA Beograd (hereinafter EDB) has been very intensive. For the purpose of better illustration thereof, single line diagrams of the composite network in the “initial year 1933“ (complete consumer area of Belgrade) and simple basic network in the “final year 2005“ (at around 5% of the consumer area EDB are presented in Fig.1 and Fig.4; namely, on the territory of the municipality of Stari Grad the total number of 10/0.42 kV substations is now more than 20 times larger, and the load densities in MW/km² are now on the average more than 100 times larger, compared to 1932.

The following Table I shows the growth of population, households and apartments, employment and adequate capacities in 10/0.42 kV substations, in the period from 1971 to the present day, in addition to the total peak loads of all consumers on the territory of the Stari Grad municipality.

Table I – Achieved parametres with the peak power forecast for the municipality of Stari Grad

Ord. No	Parametres	Achieved					Forecast	
		1971	1981	1991	2001/02	2011	2020	2030
1	Total population	83,742	71,893	68,564	61,327	48,051	50,000	60,000.
2	Total households	33,909	28,726	27,032	24,802	21,601	26,000	29,000.
3	Apartments with district heating	594	3,064	12,000	21,705	21,690	25,000	30,000.
4	Apartments without district heating		22,932	14,718	6,631	6,900	5,000	3,000.
5	Apartments with gas heating	-	-	-	-	-	-	/
6	Large credit consumers (MW)	-	-	29.50	29.1	31	35	40
7	Large credit consumers(M Wh)	-	-	70,000	66,000	71,000	80,000	100,000.
8	Employment in all forms of property	87,197	115,583	105,024	69,809	89,000	160,000	210,000.
9	Peak load (MW)	46	78	106	117	121	130	160
10	Specific load(W/per capita)	549	1,085	1,546	1,907	2,520	2,600	2,700.
11	Consumer area km ²	7	7	7	7	7	7	7
12	Load density (MW/km ²)	6.6	11.2	15.2	16.7	17.3	18.6	22.8

13	Total 10/0.4 kV substations (pcs)	136	162	245	300	320		
14	Total 10/0.4 kV substations (MVA)	-	135.36	166.73	203.42	230		
15	Private 10/0.4 kV substations (pcs)	-	-	63	54	62		
16	Private 10/0.4 kV (MVA)	-	-	56.03	49.36	53.06		

Apparently, the total number of inhabitants has been decreasing so far, as a consequence of an increasing number of business buildings and it is envisaged that notable development of apartment buildings in the municipality of Dorćol starting from the confluence of the Sava River into the Danube and from the Danube to the Cara Dušana Street will take place only after the year 2010. Increased specific load (load per capita) up to 2,500 W/per capita has been foreseen by the year 2030 as well as average load density in the municipality of Stari Grad up to 22 MW/km².

The state of the medium voltage network in 1995

In the period from 1991 to 1995, following a five-year term of unstable political events in the country and in anticipation of the embargo imposed on the Federal Republic of Yugoslavia (as a repressive measure caused by the ongoing war in the South Slavic region), thereby relying on electricity consumption in the scope of the whole national energy policy, analyses were made within EDB in respect of the future consumer power supply security indicating all insecure directions in the 10 kV network regarding the loads of the total EDB consumer area ranging from 1600 MW to 1800 MW, which resulted in an inevitable extension of almost all routes in the 10 kV network of the urban consumer area EDB - naturally, in the scope of insufficient financial assets for construction of all required 110/10 kV substations; for that pupose, computer programs were developed for the arrangement of the

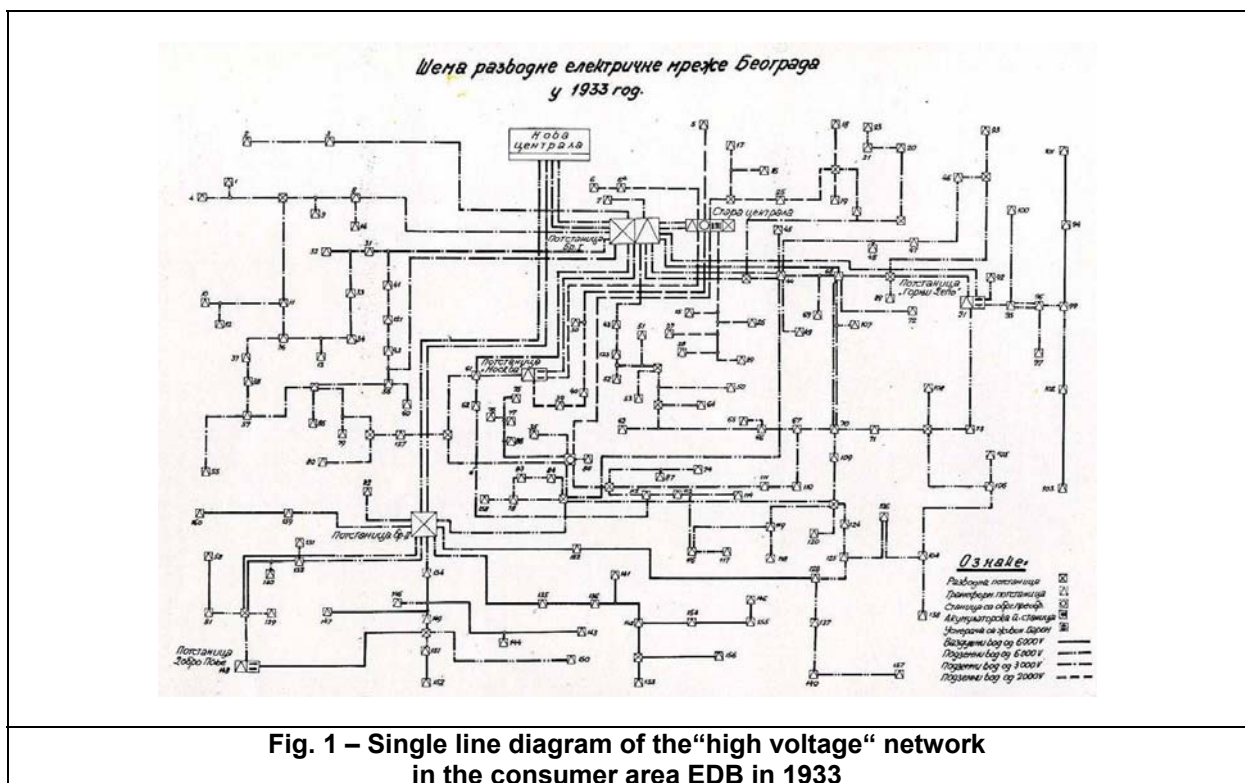

Fig. 1 – Single line diagram of the “high voltage” network in the consumer area EDB in 1933

10 kV network under the circumstances of extreme load increase among all X/10 kV sources in the consumer area EDB, which had been loaded by around 58 % in the early 90's of the past century, but also partly by overloaded plants, particularly in the central urban municipalities!!!

Table II : Proportional load of 10 kV connection cable lines in the urban area EDB in 1995

Total proportional loads of connection cable lines	Proportional share in the total number of 10 kV lines
Up to 20 %	3 %
21 to 40 %	4 %
41 to 60 %	24 %
61 to 80 %	15 %
81 to 100 %	23 %
101 to 120 %	15 %
121 to 140 %	8 %
141 to 160 %	3 %
161 to 180 %	0 %
181 to 200 %	3 %
Over 200 %	2 %

In the period from 1996 to 2000, all interventions in the 10 kV network were completed according to the basics obtained by computerized analyses, on the principles that in regions with load densities up to 10 MW/km² cables 10 kV would be laid down in the order of one along the streets, and in regions with load densities exceeding 20 MW/km² medium voltage cables 10 kV they were laid down on the principles that one cable would be laid down along one side of the street and another cable 10 kV along the other side of the street; this is how load densities exceeding 70 MW/km² were accepted on the territory of the Stari Grad municipality, where two medium voltage cables 10 kV were laid down only in around 33 % communication lines on the territory of the Stari Grad municipality!!!

Adequate analyses of load densities on the whole urban part of the consumer area EDB, with existing load densities on the level of administrative municipalities ranging from 1 MW/km² to 70 MW/km², thereby exposing the maximum of Gauss's law on the normal distribution ranging from 5 to 10 MW/km², with numerous and "free surfaces" due to the belonging park areas and squares, have shown that construction of the 10 kV medium voltage network based on these principles (obtained by developed computer programs) enables the sources of 10 kV voltage to accept as much as two times greater loads with mutual average distances between the sources of around 2 km and lengths of individual 10 kV connection cables from 2 km up to a maximum of 4 km ! Whatsoever, the 10 kV network is then shaped exclusively as a connection network between all the existing X/10 kV sources !!!

It is naturally assumed that the next step is to increase the capacities of installed power of sources in places (see Table IV) which, due to the already reached peaks of installed power in respect of 35/10 kV transformers of 12.5 MVA and 35/10 kV substations of 50 MVA, imposes the reconstruction of all existing 35/10 kV substations in the existing plants into state of the art 110/10 kV substations with 40 MVA energy transformers and total power of 110/10 kV substations in the order of 80 MVA or 120 MVA.

Techno-economic analyses have shown that this method of construction is much more acceptable than the variant of transition to the 20 kV medium voltage network with sources in 110/20 kV substations, and that this style of construction of the 10 kV medium voltage network is also more acceptable from the aspect of network length optimization compared to the 20 kV network variant!!



Fig. 2 – Single line geographic diagram of 10 kV medium voltage networks on the territory of the Stari Grad municipality in 1995

Table IV : Distribution of proportional loads of X/10 kV substations in the consumer area EDB in 1995

Total proportional loads of X/10 kV substations	Share in the total installed power of X/10 kV substations in the consumer area EDB
Up to 50 %	399.6 MVA
51 to 60 %	193 MVA
61 to 70 %	415.5 MVA
71 to 80 %	255.5 MVA
81 to 90 %	509.5 MVA
91 to 100 %	603 MVA
101 to 120 %	56.5 MVA

Methods for developing a computer program intended for medium voltage network arrangement

The basic principles for arrangement of the 10 kV network in the consumer area of the new 110/10 kV substation which is interpolated between several X/10 kV substations by being placed in the focus of the load, are grounded on the method of forming the 10 kV connection lines between the new source and the existing sources which is the essence of the computer program method; namely, if around the direction there are two connecting sources 110/10 kV e.g. 30 reception substations 10/0.42 kV which should be connected by means of the shortest network, e.g. by means of 3 connection lines 10 kV with the sources, it is then apparent that what should be done is to establish the shortest distance of each reception substation 10/0.42 kV from the straight line connecting the 110/10 kV sources, and then assort 10 reception substations 10/0.42 kV which are the most remote ones from this straight line and connect them by a "broken line" both mutually and with the 110/10 kV sources, and then assort the following 10 substations 10/0.42 kV and connect them both mutually and with the sources, and finally the third group of reception substations 10/0.42 kV (which are closest to the straight line connecting the sources) and connect them both mutually and with the sources 110/10 kV.

It is assumed that the database shall include the coordinates of each reception substation 10/0.42 kV, as well as the coordinates on the position and source 110/10 kV; the new source shall thereby be placed in the centre of all reception substations 10/0.42 kV between the selected number of existing sources X/10 kV, and shall be connected by straight lines with the existing sources – and in relation thereto the distances between the reception substations 10/0.42 kV from the straight lines shall be thereby determined.

The favourable option here would be to apply the polar coordinates in the common coordinate system and, by means of analytical geometry and in conventional relations, determine the “shortest distance between the points and the straight line”; it is thereby possible, in a developed computer program, to use the program “BACK TRACKING” logics for mutual connection of reception substations 10/0.42 kV provided that in “all the tested combinations” the total length of each connected line should be minimal!

Strictly speaking, in that case each 10 kV connection line between two sources is the shortest, but there is also a great chance that the total length of the whole network in the arrangement zone will be minimal, naturally if a somewhat less even distribution of 10/0.42 kV reception substations is permissible along 10 kV in each direction between 110/10 kV sources; in that case, the computer program is “permitted” to perform iterations of the complete program in the desired number thereof.

Such orientation in selecting the 10/0.42 kV reception substations which need to be connected both mutually and with the 110/10 kV sources significantly reduces the total number of calculating combinations and it is therefore possible to obtain by computerization, in an acceptable time span, an objective network arrangement, thereby varying the total number of TS 10/0.42 kV reception substations along the 10 kV connection lines.

The following part of this paper shows the computerized 10 kV network arrangement in the consumer area of the future 110/10 kV Substation Centar, with an even distribution of 10/0.42 kV reception substations along the exclusive 10 kV connection lines between several 110/10 kV sources; whereas the future 110/10 kV substation is in the focus of all 10/0.42 kV substations in the arrangement zone; it also shows the arrangement of the 10 kV network also without 110/10 kV Substation Centar – but with reconstruction of “enforced” surrounding X/10 kV sources.

The following Table V shows the total length and total number of exclusive connection lines 10 kV in the consumer area of the future 10/0.42 kV substation in exclusive 10 kV connection lines with the neighbouring X/10 kV substations; it is evident that the total network length is reduced by around 25 % if the total installed power of 10/0.42 kV reception substations along the connection lines increases with a step of 1 MVA, and that the total number of connection cable lines leaving the 110/10 kV Substation Centar is thereby considerably reduced!!!

Table V : The total length and the total number of 10 kV exclusive connection cables

In the consumer area of the future 110/10 kV Substation Centar in the function of the permissible installed power of 10/0.42 kV substations in 10 kV exclusively connected lines with the neighbouring X/10 kV substations

Total installed power of 10/0.42 kV substations in connection lines	Total length of exclusively connected 10 kV network	Total number of connection lines leaving 110/10 kV Substation Centar
Do 4 MVA	156 %	35
DO 4.5 MVA	136 %	32
DO 5 MVA	125 %	28
DO 5.5 MVA	116 %	23
DO 6 MVA	100 %	22

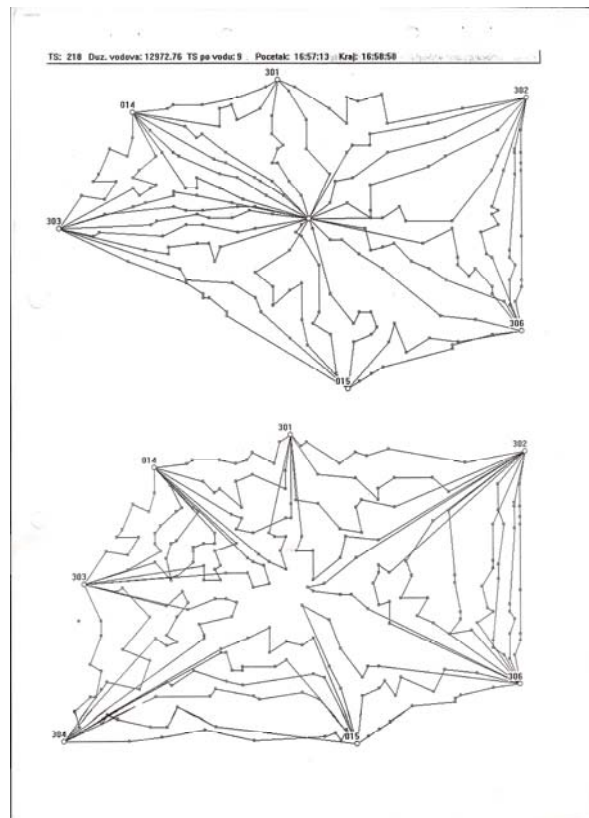

Fig. 3– Single line geographic diagram of the 10 kV medium voltage network on the territory of the municipality of Stari Grad obtained by computerized arrangement, with and without 110/10 kV Substation Center

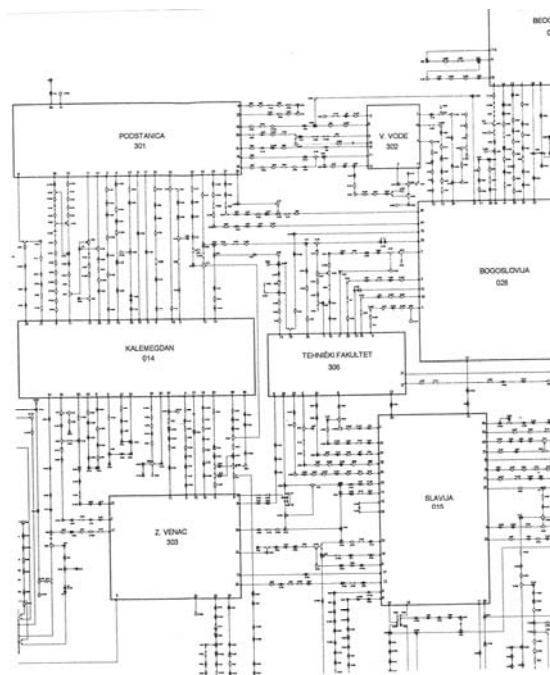

Fig. 4 – Single line diagram of the medium voltage 10 kV network on the territory of the very centre of Belgrade, in the administrative municipality of Stari Grad in 2005

Distribution of proportional loads of 10 kV connection lines in the complete urban part of the consumer area EDB in 2001 and 2010

Here are presented proportional loads of all 10 kV connection lines in the urban consumer area EDB in the period from 1971 to 2010, in order to conclude, by comparing the distribution in the above period, about the effects of all taken measures on the shaping of the 10 kV network in connection directions between all X/10 kV substations in the whole urban consumer area EDB in the period after 1995; namely, already around the year 2000 all directions in the 10 kV connection network in many microregions of the urban network were recovered, so that in 2010 only around 7% of connection lines 10 kV were in a state of jeopardized security, i.e. proportional loads above 100 % (as the connection lines consist of two 10 kV connections supplied from different X/10 kV sources with a supply "limit" somewhere around the electrical half of connection lines– for that reason the first 10 kV cable sections have not been overloaded in the recent winter periods).

In the forthcoming period of 10 kV network construction, the operation safety of the whole 10 kV urban cable network will surely be brought to a satisfactory level, for which purpose it is also necessary to construct several 110/10 kV substations on the principle of interpolation between several existing X/10 kV substations, first of all 110/10 kV substations Centar, Braće Jerković, Olimp, Galovica, Blok 32, Altina ...etc., and only after that to begin with transformation of almost all 35/10 kV substations in the urban consumer area into state of the art 110/10 kV substations (of course, in the existing buildings); it is only possible by constructing new network facilities to bring the average age level of X/10 kV substations in the consumer area EDB (in 2010 about 37 years) to the required level, and by transforming extremely old 35/10 kV substations in the urban consumer area into new state of the art 110/10 kV substations in the existing plants, this is most efficiently achieved.

Tabela VI : Proportional load of 10 kV connection cable lines
in the urban area EDB in the period from 1971 to 2010

	1971	1981	1991	2001	2010
to 20 %	8 %	3 %	3 %	0 %	0 %
21 to 40 %	10 %	15 %	4 %	0 %	0 %
41 to 60 %	21 %	17 %	26 %	12 %	0 %
61 to 80 %	33 %	27 %	20 %	31 %	35 %
81 to 100 %	8 %	26 %	24 %	40 %	58 %
101 to 120 %	15 %	7 %	16 %	12 %	5 %
121 to 140 %	3 %	3 %	7 %	5%	2%
141 to 160 %	2 %	2 %	0 %	0 %	0 %
161 to 180 %	0 %	0 %	0 %	0 %	0 %

Conclusion:

The paper presents the methods for devising a computer program intended for medium voltage networks arrangement in the consumer area of new sources of power distribution voltage, and also the effects of all taken measures in EDB in order to bring the 10 kV network operation safety to the desired level; if it helps in producing even faster and more powerful computer programs, not only in EDB, based on completely exact, unbiased and precise decision-making in respect of network shaping – the paper will have achieved its purpose.

literature: With energy up to the year 2000, Journal «Ektrodistribucija»,

(1) T. Milanov, D. Milanov – Arrangement of the high voltage network in Belgrade, JUKO CIGRE ,2002, Zlatibor

(2) T. Milanov, D. Milanov, Rasplet visokonaponske mreže Beograda, JUKO CIGRE, Zlatibor 2002.

